

WARRANTY CONDITIONS

This extended warranty only covers Caroma Industries Limited ("Caroma") products, and does not extend to products which you have selected outside our Product range.

This extended warranty only applies to defects which have arisen solely from faulty materials or workmanship in the Products and does not apply to other defects which may have arisen as a result of, without limitation, the following: accidental damage, abuse, misuse, maltreatment, abnormal stress or strain, harsh or adverse weather conditions, including excessive water pressure or temperature, or neglect of any kind of the Products. Alterations and repairs of the Products other than by an accredited and licensed service agent or technician are not covered. For the avoidance of doubt, attachment of accessories or use of non-genuine replacement parts other than those manufactured or approved by Caroma are not covered by this extended warranty.

This extended warranty for the Products commences from date of purchase or for new buildings on the date of handover for the relevant period set out in the warranty periods table.

In addition to this extended warranty, certain legislation (including the ACL) may give you certain rights which cannot be excluded, restricted or modified, this extended warranty must be read subject to such legislation and nothing in this warranty has the effect of excluding, restricting or modifying those rights.

Warranty Claims

To make a warranty claim, the following documentation must be posted or faxed to Caroma (contact details listed below):

- Proof of Purchase ("POP");
- handover documentation for new homes,
- Warranty Certificate or equivalent documentation must be supplied for warranty claims to be considered.
- Your contact details.

If the Product has not been installed, the Product can be returned with POP, to the place of purchase. If the cost of returning any defective parts is unreasonable, please contact Caroma on the telephone number listed below so that, if appropriate, we can arrange a collection.

Caroma Industries Limited contact details are as follows:

GWA Bathrooms & Kitchens
Locked Bag 5005,
Baulkham Hills BC,
NSW 2153
Phone: 13 14 16
Fax: 1800 818 346
enquiries@caroma.com.au

NOTE: The extended warranty only applies to the original owner and is not transferable.

Should any warranty claim be made and attended to by a Caroma authorised Service Agent and that in the opinion of the Service Agent or Caroma, the problem was from faulty installation or use of the Products in conjunction with products of another manufacturer or from some other cause other than a manufacturing defect of the goods for which Caroma is responsible. Caroma Industries Limited reserves the right to charge a service fee for each service staff attending the premises where Products have been installed.

As part of Caroma's commitment to continuous improvement, Caroma reserves the right to make changes to its Products at any time.

Caroma requires adequate access to Products, fittings and fixtures to undertake extended warranty repairs. Caroma will not be responsible for any consequential damage or costs where adequate access to Product fittings & fixtures is not accessible.

Caroma reserves the right to provide minor components as 'Parts Only' to the customer.

Consequential loss

To the extent permitted by law, Caroma will not be liable for any loss or damage to furniture, floor coverings, walls, fixtures or any other consequential loss of any kind caused by any defect in the Products or components.

This Extended Warranty shall be void for the following reasons:

1. A customer's inability to provide POP or equivalent documentation.
2. If:
 - Products are not installed by a licensed plumber and/or electrician.
 - Products are not installed to relevant National Standards and State Regulations.
 - Products are not installed in accordance with the manufacturer's installation instructions.
 - Water pressures and or temperatures that exceed stated limitations as per the product installation instructions.
 - Fair wear and tear, including scratching from cleaning etc.
 - Inappropriate or non-approved connection fittings connecting Products to sewer.
 - Non written approved modifications to the Products.
 - Products used for incorrect applications, non-potable water etc.
 - Damage as a result of obstructions due to inadequate flushing of system before use and problems caused by water supply (including silt, corrosion and excess water pressure).
 - Service or repairs with non-standard replacement parts previously undertaken without Caroma written approval.



In Australia
For more information call 1300 CAROMA
or go to www.caroma.com.au

* For full warranty terms and conditions,
please visit www.caroma.com.au

In New Zealand
For more information call 09 279 2700
or go to www.caroma.co.nz

* For full warranty terms and conditions,
please visit www.caroma.com.au

© Copyright 2012. Caroma Industries Limited.
ABN 35 000 189 499
All rights reserved.

Caroma®

Contura Solid Surface Freestanding Bath Care & Installation Guide

This manual has to be left with the end user

WARNING:

Before commencing installation, please read these instructions carefully. Installation must comply with all State By-Laws and any requirements imposed by local authorities.



Congratulations on the purchase of your new Caroma Contura Freestanding Bath made from Solid Surface. We trust you will enjoy many years of relaxation in your beautiful new bath.

Solid Surface is an advanced composite material consisting of natural stone and an acrylic resin. As stone is a natural product there will be slight variations in the finish under certain light conditions. We believe these natural variations add to the uniqueness of each bath's character.

CARE OPTIONS

EVERYDAY CARE

- Caring for your Solid Surface bath is quick and easy. For day to day cleaning, most dirt can be removed with a damp sponge and soapy water.
- For harder to remove stains a mild abrasive cleaner such as Jif or Gumption may be used.
- When coloured essential oils are used always add oils to the water, never pour them directly into an empty bath.

THINGS TO REMEMBER

- Compliance with AS.3740 Waterproofing of wet areas within residential buildings applies when installing baths.
- Water test the bath prior to enclosing to ensure it drains correctly as no claims for non-draining baths will be valid after enclosing or tiling has been done.
- All materials used to comply with appropriate Australian and New Zealand standards.
- Installation must comply with appropriate building codes and local authority requirements.

Note: All dimensions are in millimeters and are subject to normal manufacturing variations. Therefore Caroma reserves the right to vary specifications without notice.

INSTALLATION INSTRUCTIONS

BEFORE YOU GET STARTED

WARNING: Before commencing installation, please read these instructions carefully. Installation must comply with all State By-Laws and any requirements imposed by the local authorities. No putties or silicones containing linseed oil are to be used as sealants on the waste. We recommend sanitaryware grade silicone.

UNPACK AND CHECK FOR DAMAGE

After receiving your bath, please unpack and check carefully for any damage. Repack the bath if it is not being immediately installed. Caroma reserves the right to reject any claim for damage if not notified in a timely manner.

PROTECT YOUR BATH

Before commencing installation, ensure the bath is completely protected. Scratches, cracks and chips incurred during installation are not covered by the warranty.

STEP 1

Smart Seal installation. We recommend use of the Smart Seal as it allows watertight installation without access to the waste. Mark outline of bath in final install position.

STEP 2

Use the markings on the floor to determine the waste position relative to the smart seal. Using a Ø30mm hole saw cut a hole through the top foam and rubber seal of the smart seal. Finally using a Ø40mm hole saw cut a hole in the same position, but only through the foam layer (do not touch the rubber seal).

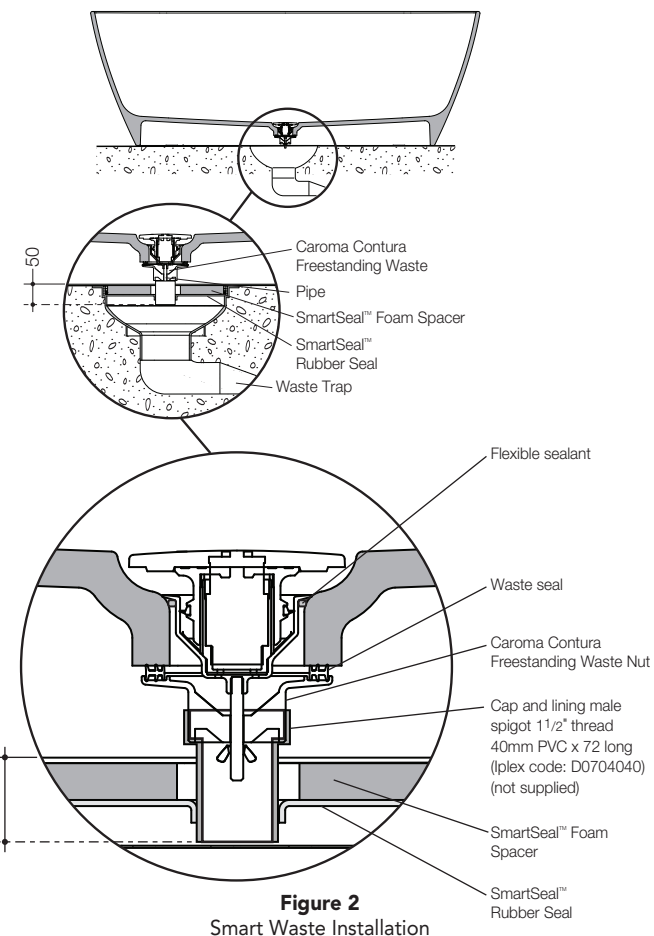

Figure 2
Smart Waste Installation

STEP 3

Tilt bath on side onto a clean surface to protect against damage. Apply silicone to pop-up waste body and install waste into bath ensuring the cap is centralised into the bath waste hole properly. Fit Ø40mm straight waste pipe to the bottom of the pop up waste. Ensure that the pipe extends exactly 50mm past the base of the bath, ensure that end is smooth and slightly radius for a smooth insertion into smart seal.

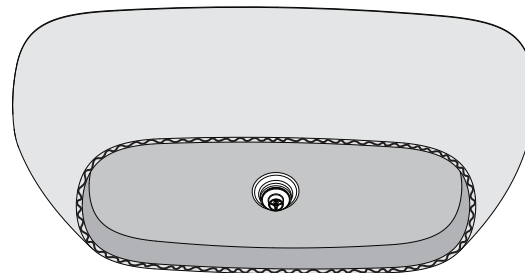

Figure 3

Apply silicone on bottom of bath as shown.

STEP 4

Level the bath and apply silicone to the bottom surface and around rubber seal in smart seal. Carefully lower bath into position ensuring that the waste pipe engages into smart seal. Do not fill bath with water at this stage. Leave to set for 24 hours before filling and checking for leaks

WARRANTY CONDITIONS CONTINUED

- Damage to finishes by adhesives, sealants or abrasive cleaners etc.
- Damage to finishes which arise from installation or post installation use.
- Damage due to abuse as determined by authorised Service Agent or Caroma.
- Failure to observe manufacturers care and cleaning instructions.
- The extended warranty work is limited to the pre-approved scope of work that will be set out in a work order. Additional work will require authorisation from Caroma.

Except to the extent that a customer can demonstrate that at the time of purchase the product was faulty or defective and at that time the customer was not aware of such fault or defect.

Note: It is the installer/consumers responsibility to ensure:

- Product is not damaged prior to installation.
- They are happy with their purchase.
- The product has all of its components.
- Required maintenance is performed.

Our Products come with guarantees that cannot be excluded under the Australian Consumer Law. You are entitled to a replacement or refund for a major failure and compensation for any other loss or damage. You are also entitled to have the Products repaired or replaced if the Products fail to be of acceptable quality and the failure does not amount to a major failure.

GWA BATHROOMS & KITCHENS WARRANTY PERIODS

While all Caroma Industries Limited ("Caroma") products are manufactured to the highest standard, in addition to the guarantees provided under the Australian Consumer Law (Schedule 2 to the *Competition and Consumer Act 2010* (Cth) ("ACL"), we offer varying extended warranty periods (please refer to below table) from the date of purchase or handover that our Products are free from all defects in materials and workmanship, subject to the terms and conditions that follow, for additional peace of mind. We are committed to upholding our position as Australia's leading Quality Supplier, Technical Support & Customer Service Team, with a dedicated and proven service network striving for ultimate customer satisfaction.

For all After Sales & Service enquiries please contact GWA Bathrooms & Kitchens on 13 14 16.

BATHS		
Range	Warranty	Comments
CAROMA		
Baths - Solid Surface	10/1 Years	10 years bath shell & 1 year labour